

Gem Quad Products

P.O. Box 291, Boissevain, Manitoba
Canada R0K 0E0
Tel. (204) 534-6184

Manufacturers of:
Gem Quad Ham Antennas

INSTALLATION OPERATING AND MAINTENANCE INSTRUCTIONS

GEM QUAD ANTENNA

for 10, 15 & 20 meters

CHECK OFF LIST!

You are now the owner of a genuine Gem Quad Antenna, before starting to assemble, please check off all the parts in the kit against the parts list on this page. Identify all parts against the list and/or the figure of the Quad, page 2.

TWO ELEMENT GEM QUAD

- 8 Fibreglass Arms
- 4 Tie Rods 80" long (Fibreglass)
- 3 Spools of Wire "MD"
- 3 Spools of Wire "MR"
- 16 Stainless Steel Clamps
- 24 Tension Tubes
- 1 Toroid Balun Kit
- Stub Kit - containing
 - 1 Spool of Wire for Stubs
 - 1 Length of Nylon Cord
 - 6 Stub Spacers
- 1 Packet of 64 Self-Locking Nylon Straps
- 1 Aluminum Spider

THIRD ELEMENT FOR GEM QUAD

- 4 Fibreglass Arms
- 4 Tie Rods 80" long (Fibreglass)
- 3 Spools of Wire "MDIR"
- 8 Stainless Steel Clamps
- 12 Tension Tubes
- 1 Boom-To-Mast Mounting Stub (Aluminum)
- 1 Boom
- Stub Kit - containing
 - 1 Spool of Wire for Stubs
 - 1 Length of Nylon Cord
 - 6 Stub Spacers
- 1 Packet of 32 Self-Locking Nylon Straps
- Third Element Spider (Aluminum)

FOURTH ELEMENT FOR GEM QUAD

- 4 Fibreglass Arms
- 4 Tie Rods 80" long (Fibreglass)
- 3 Spools of Wire "MDIR"
- 8 Stainless Steel Clamps
- 12 Tension Tubes
- 1 Boom-To-Mast Mounting Stub (Aluminum)
- 1 Boom
- Stub Kit - containing
 - 1 Spool of Wire for Stubs
 - 1 Length of Nylon Cord
 - 6 Stub Spacers
- 1 Packet of 32 Self-Locking Nylon Straps
- Third Element Spider (Aluminum)

NOW READ ALL INSTRUCTIONS BEFORE PROCEEDING WITH ASSEMBLY.
CAUTION — PROTECT YOUR HANDS FROM CUTS AND ABRASIONS, WEAR GLOVES.

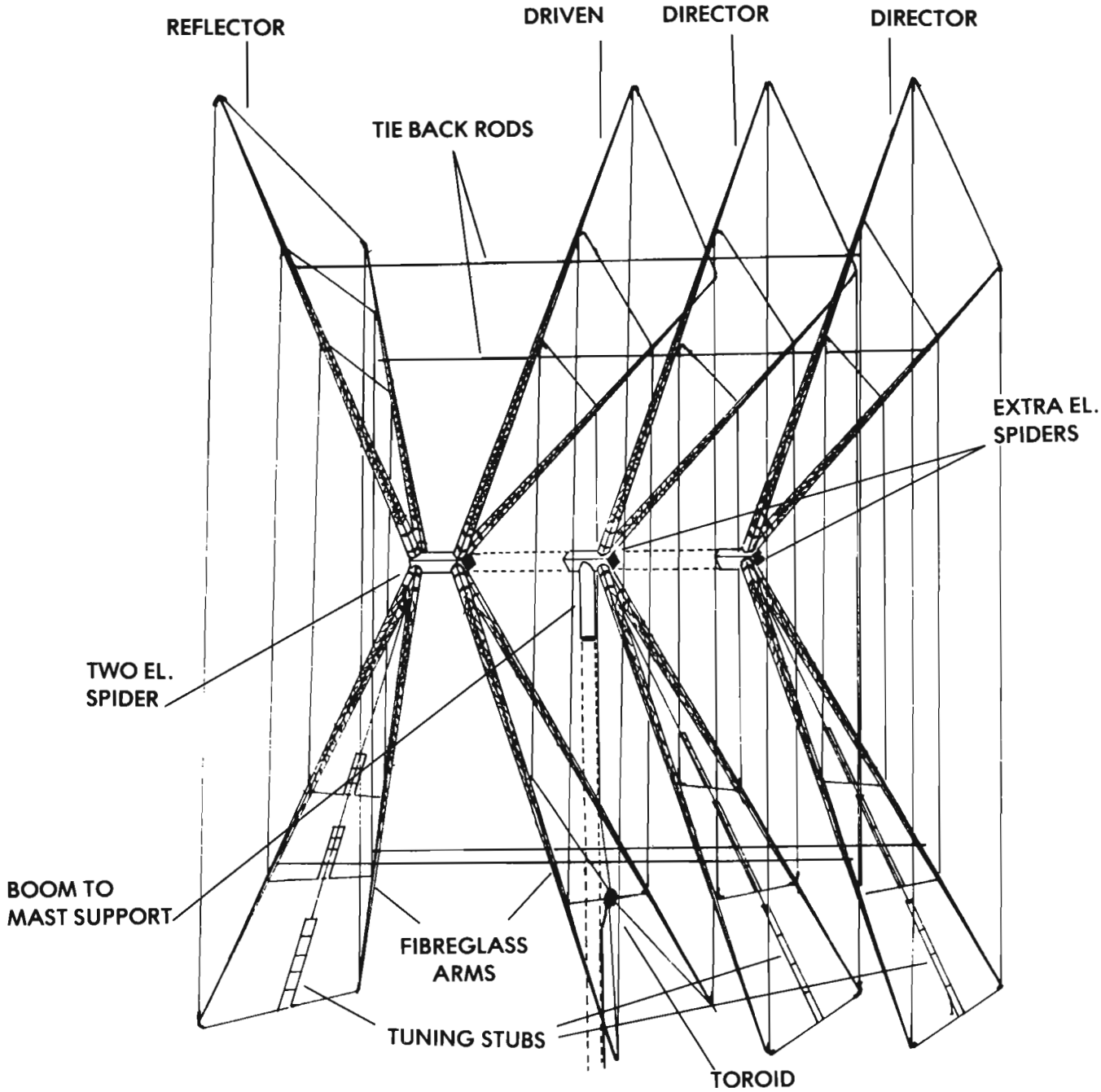

STEP 1: PREPARATION OF ARMS

Lay all fiberglass arms on flat surface, making sure that all colours show. Attach a nylon tension tube at each "black" mark on one of the arms, using two nylon straps at the 10 meter, 15 meter, and 20 meter positions. (See Fig. 1 & Fig. 2). The 20 meter nylon strap encircles all three fiberglass rods. These straps should be pulled tight with pliers and the end snipped off. Make sure position is correct before permanently attaching. Preferably after wire is strung. See Step 5.

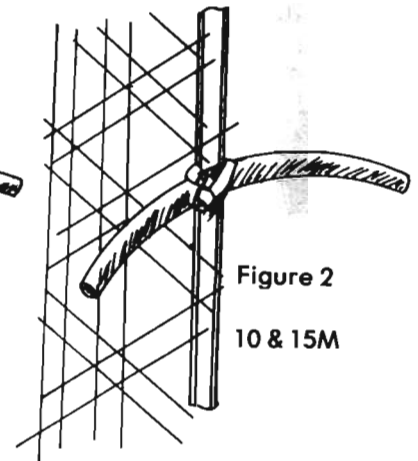
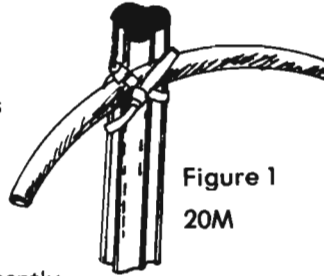

Be sure that you affix the straps in such a manner that the tube will lay flat against the triangular arm, on the side marked at the base with a red or blue stripe of paint. The tension tubes themselves should cover the narrow stripes of black paint used as markers.

Place two of the large stainless steel clamps over the large end of the Quad arm and tighten just enough to hold them in place, without squeezing the three rods.

Repeat the above with each arm until all eight are complete and properly prepared for installation on the spider.

STEP 2: ANCHOR ALUMINUM SPIDER

Place spider on a three to six foot rigid post or platform with the square central tube of the spider in a vertical position. The aluminum stub arms with "red" markings should be facing up. If you are using a tilting tower, then the spider can be attached to this for assembly with appropriate orientation of the assembly instructions. A short stepladder makes a good stand.

STEP 3: ATTACH UPPER (REFLECTOR) ARMS TO SPIDER

Four of the fiberglass arms have "red" markings on the large end. Slide these arms onto the spider stubs, lining up with the "red" markings on the arms. Push each arm on as far as possible. Secure with the two stainless steel clamps supplied. DO NOT tighten a clamp over the wrapped portion of the arm, as this prevents a close and tight fit. The aluminum tube should fit into this wrapped portion. (See Fig. 3 for detail of arm to spider).

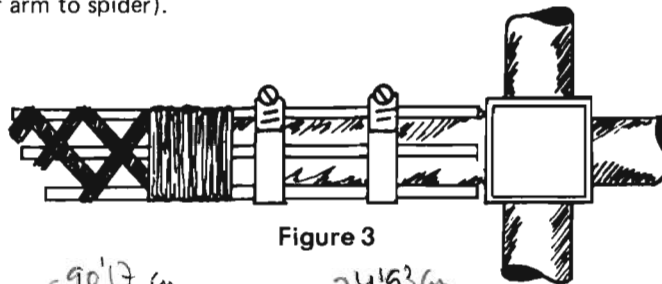

STEP 4: MAKE UP STUBS (Note - clean wire before using)

From the packet, cut one wire $35\frac{1}{2}$ " long and two wires $29\frac{1}{2}$ " long. Taking the long wire attach one end to the end of a stub spacer, No. 1, using $1\frac{1}{4}$ " of wire to do so. Thread a second spacer on the other end of the wire, No. 2, then attach the free end of the wire to the opposite end of your first spacer, No. 1. Adjust wire and spacers to make an open-ended loop of wire. Repeat with the other two pieces of wire. (See Fig. 4).

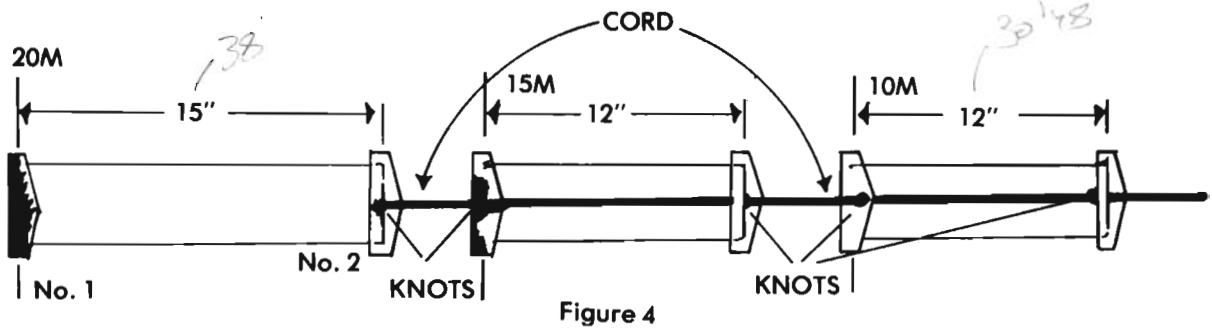

Tie the piece of nylon cord to the stub, No 2. See Fig. 4. Then thread it through each successive stub putting a knot on every stub, adjusting the knot so that the proper spacing between stubs is achieved. Remember to place the stubs in the quadrant which will be nearest the ground when unit is in use.

SOLDER JOINTS. Note: Plastic is designed to be weather proof but is susceptible to heat. Remove tension from wires when soldering.

STEP 5: THREAD WIRES

Take the spool of wire marked "10MR" attach one end to the stub with the short loop and thread the wire through the four nylon tubes (Fig. 5) closest to the spider, attaching the other end of this wire to the opposite end of the stub.

NOTE: The wire may appear short due to the arms being flexed toward the spider while in the assembly position. Do not lengthen wire. If necessary release one tension tube in order to make the connection on the stub, then re-connect the tension tube in its proper position.

Proceed to thread the next four tubes in the same manner, using the spool of wire marked "15MR". Secure the ends of the wire loop to the other small stub at the open spacer end. These stubs must all be in the quadrant which will be closest to the ground when the unit is in use.

Finally, the outer four tubes will be threaded with the wire from the spool marked "20MR". Attach the ends of the wire to the open spacer of the larger stub. Solder all joints.

Tie nylon cord to spider and adjust till the stubs are held in the proper plane with the three elements remaining square. (See Page 6).

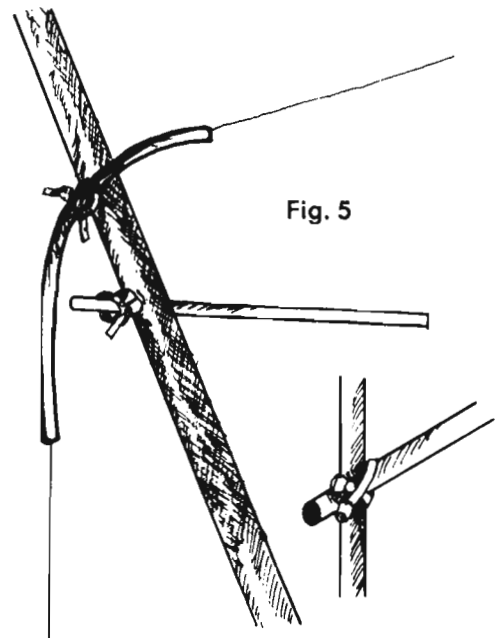

STEP 6: CONNECT THE RODS TO UPPER ARMS (Fig. 5)

The four 1/4" tie rods, 80 inches long and coded yellow, must now be connected to the yellow marks on the upper arms. Connect the tie rods to the arms using the nylon straps, two per point of attachment, as supplied for the tension tubes. Let the rods hang down vertically at this time. These rods are an important part of the design strength of the GEM QUAD. It is, therefore, wise to make sure that the rod protrudes through the nylon strap at least 1-1/2 inches and that it is gripped very firmly in the straps. (See Fig. 5). Drilling a small hole at each end of the tie rod and inserting a cotter pin is a good insurance that it will not slip off, a necessity in high wind areas.

STEP 7: ATTACHING LOWER (DRIVEN) ARMS

It will be necessary to raise the spider to about 6 feet, still with the "red" marks uppermost and the "blue" marks down. Attach the remaining arms to the spider in the same manner as before, making sure that all are firmly secured.

NOTE: The wires may appear slack. Do not cut wires as the slackness will be eliminated when the antenna is in its operational position and tie back rods in place.

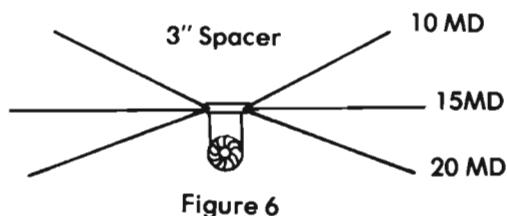

STEP 8: THREAD WIRE THROUGH NYLON TUBES

Take the spool of wire marked "10MD" and beginning from the area opposite the stubs, thread the wire through the four nylon tubes closest to the spider. Thread the wires so that they will be in the Quadrant nearest the ground when antenna is in operating position. Proceed to thread the other two elements in their appropriate positions, using the "15MD" and "20MD" spools. Connect all elements to the two holes in the plastic spacer, provided in the TOROID KIT. (See Fig. 6).

STEP 9: INSTALL TOROID BALUN

Refer to the instructions supplied in the Toroid Kit and prepare the balun as suggested. It has been found that by covering the balun core with black plastic tape prior to winding the coil, the effects of weather can be minimized.

STEP 10: CONNECT TIE RODS TO LOWER ARMS

The tie rods must now be connected to the four lower arms in the same manner as Step 6. (see Fig. 5). This adjustment will give strength to the assembly and keep the wire elements in a state of tension. Tie rods should also be adjusted to give a slight "bow" to the tips of the arms.

TUNING:

STEP 1: TUNING THE ANTENNA (For F/B Ratio)

The driven element is "pre-tuned", but due to variance in height of operation, proximity of ground mass, etc., it may be desirable to tune the reflector stubs of each band. This is done very simply by directing the assembly away from a local station transmitting a signal on the desired optimum band frequency. (This should be close to **14.200, 21.200, or 29.000** Mhz.) Short out the stub of the band on which you are receiving until your "S" meter shows the minimum signal. This should be the position of your best back to front ratio. The best forward gain will be apparent at a slightly higher frequency. Alligator clips on a 2" piece of wire make a good "short".

This procedure should be repeated for all three bands, with a final check on the first one peaked up - to be sure that there has been no interaction. It has been found that interaction is non-existent, or minimal to the point of being negligible. Permanently solder shorting strips on all stubs.

F/B Tuning is important as it effects SWR.

NOTE: When tuning director stub on 3 or 4 element quads, remember to direct front of quad toward weak local signal and tune director for BEST signal on the "S" meter.

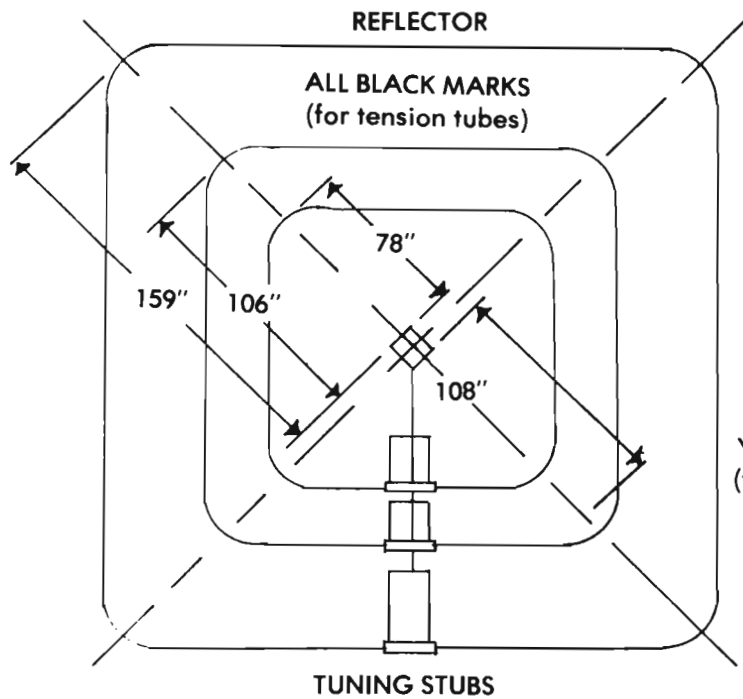

WIRE LENGTHS:

10 M.
 *MDIR - 32' 96
 MR - 35'8" 1074
 MD - 34'8" 1044

YELLOW MARKS
 (for tie back rod)

15 M.
 *MDIR - 44' 132
 MR - 48'2" 1446
 MD - 46'8" 1404

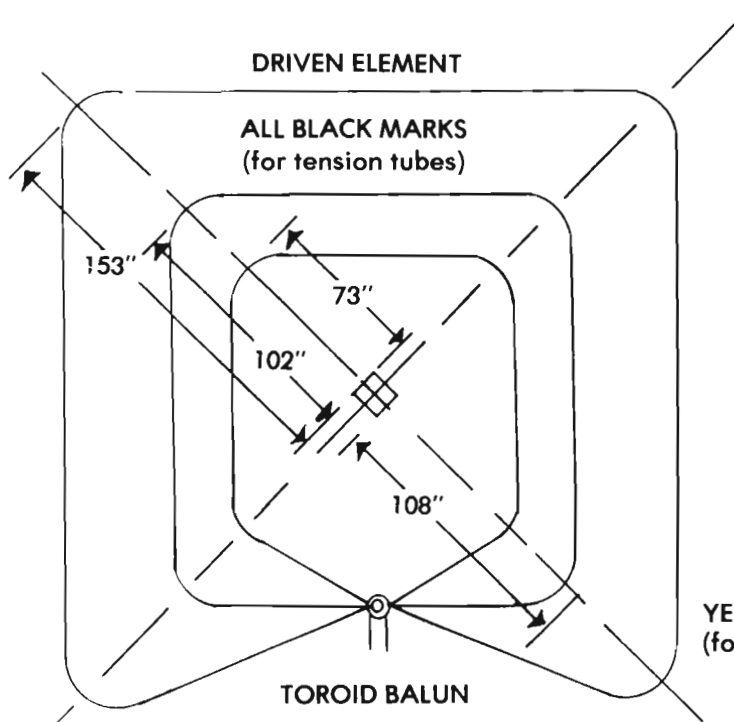

20 M.
 *MDIR - 66' 198
 MR - 71'3" 2139
 MD - 69'8" 2094

*MDIR Lengths are the same for all directors.

YELLOW MARKS
 (for tie back rod)

THIRD ELEMENT OF THE GEM QUAD

STEP 1: INSTALL NYLON TENSION TUBES

On a flat surface, prepare the four arms (as described in Step 1 of the Two Element Instructions). Lay arms on a flat surface, making sure all colours show. Attach a nylon tension tube at each "black" mark on one of the arms, using two nylon straps at the 10 meter, 15 meter, and 20 meter positions. (See Fig. 1 & Fig. 2). The 20 meter nylon strap encircles all three fiberglass rods. These straps should be pulled tight with pliers and the end snipped off.

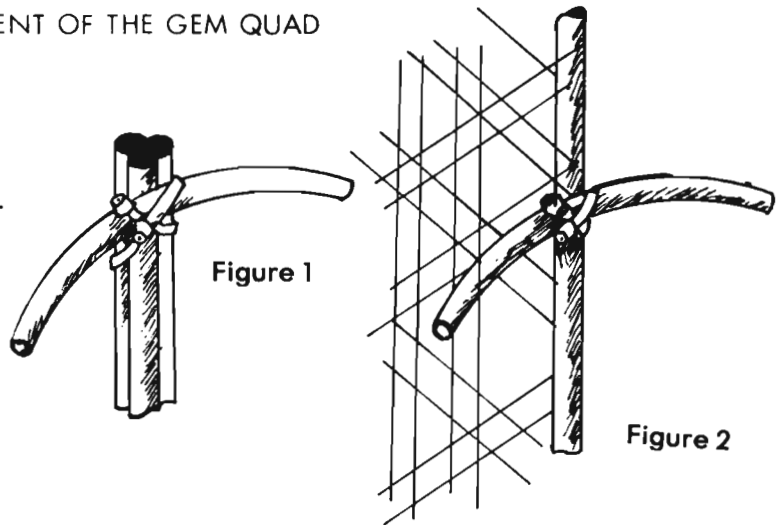

STEP 2: ANCHOR ALUMINUM SPIDER

Place the spider on a 6-foot post or platform with the square central tubes of the spider in a vertical position and the aluminum stub arms with green markings facing downward.

STEP 3: ATTACH ARMS TO SPIDER

The four arms have "green" markings on the large end. Place two stainless steel clamps over the end of each arm, then slide the arms on the stubs, pushing them on as far as possible. Secure the arms firmly with the clamps supplied. (See Fig. 3).

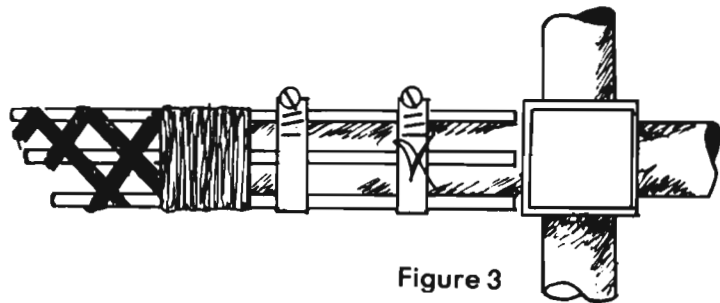

STEP 4: THREAD WIRES THROUGH NYLON TUBES

Having made up the tuning stubs as directed in Step 5 of two element quad, take the spool of wire marked "10 MDIR" and begin by attaching the wire to one side of the open end of one of the smaller stubs. Thread the wire through the four tubes closest the spider and attach the wire to the opposite side of the same stub.

Proceed to thread the two other spools of wire in the same manner, through the appropriate tubes, and attaching the "15 MDIR" to the second of the smaller stubs, and the "20 MDIR" to the larger of the tuning stubs. Solder all joints. The stubs are then suspended by the nylon cord provided.

STEP 5: ELEMENT AND BOOM ASSEMBLY

Take the boom that is supplied and insert it into the spider of the third element so that the arms are sloping away from the boom. Drill through spider and boom, and insert $\frac{1}{4}$ inch bolt and secure.

Next slide on the mast-to-boom support assembly, and bolt in position as with the spider. The centre of the support stub should be approximately 18" from the inside of the two element spider.

STEP 6:

When the complete third element is assembled, insert the boom into the square opening of the two element spider, from the Driven Element side. Drill and bolt securely, making sure that the boom is inserted 6" into the two element spider. Care should be taken to ensure that the stubs of the third element are aligned in the same plane as those of the Reflector: - The lower quadrant of the Quad in its normal position. All arms should line up properly.

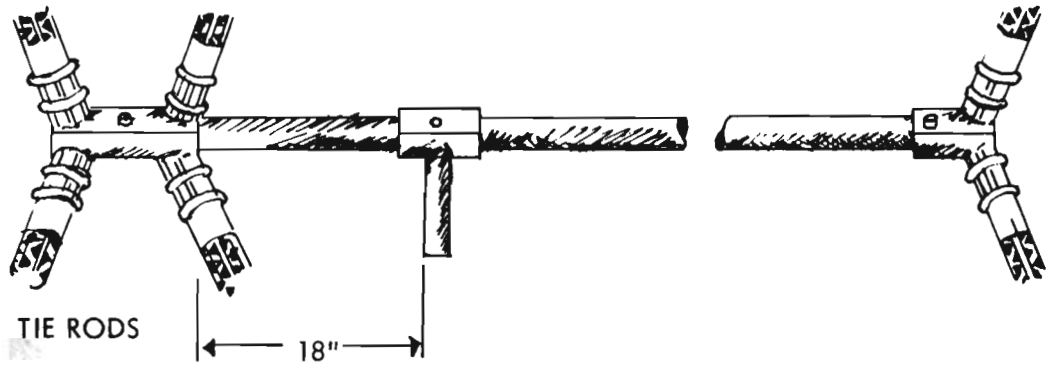

STEP 7: TIE RODS

The tie rods should be positioned close to those on the original two element antenna, maintaining an attitude parallel to the ground. This is important both from a structural point of view, and to keep the third element at the correct electrical spacing. The method of getting at the tie rod clamps is dependent upon the type of mast assembly, and as such, is left to the choice and ingenuity of the individual.

FOURTH ELEMENT INSTRUCTIONS

The following instructions are based on the fact that a Third Element Quad has already been installed, and that a fourth element is now to be added. It will be necessary to remove the boom from the three element assembly and to use the boom in the fourth element kit.

STEP 1: PREPARATION OF ARMS

Prepare the four arms as described in Step 1 of the Two Element Quad Instructions.

STEP 2: ANCHOR ALUMINUM SPIDER

Place the spider on a 6-foot post or platform with the square central tubes of the spider in a vertical position and the aluminum stub arms with green markings facing downward.

STEP 3: ATTACH ARMS TO SPIDER

The four arms have "green" markings on the large end. Place two stainless steel clamps over the end of each arm, then slide the arms on the stubs, pushing them on as far as possible. Secure the arms firmly with the clamps supplied. (See Figure 3).

STEP 4: THREAD WIRES THROUGH NYLON TUBES

Having made up the tuning stubs as directed in Step 5, take the spool of wire marked "10 MDIR" and begin by attaching the wire to one side of the open end of one of the smaller stubs. Thread the wire through the four tubes closest the spider and attach the wire to the opposite side of the same stub.

Proceed to thread the two other spools of wire in the same manner, through the appropriate tubes, and attaching the "15 MDIR" to the second of the smaller stubs, and the "20 MDIR" to the larger of the tuning stubs. Solder all joints. The stubs are then suspended by the nylon cord provided. Place the spider on a 6-foot post or platform with the square central tubes of the spider in a vertical position and the aluminum stub arms with green markings facing downward.

STEP 5: BOOM ASSEMBLY

Take the 13 foot boom supplied with the kit and centre the Third Element exactly 6 feet 0-1/2 inches from the Fourth Element, with the third element arms leaning toward the Fourth Element, Drill and secure, making sure that stubs and arms are lined up. Both third and fourth element arms will incline away from the presently unused end of the boom. Clamp the tie rods at the "yellow" marked positions, linking third and fourth elements. Put the "mast to boom" support on the boom, making sure that the stub lines up with the tuning stubs of the elements. This mounting bracket will be positioned at the side of the third element, but can be adjusted for optimum balance and least "weather cock" effect.

Remember that when the two element spider is fitted to the boom, the driven element is closest to the third element, and the reflector at the outside end of the boom.

Gem Quad Products

P.O. Box 291, Boissevain, Manitoba
Canada R0K 0E0
Tel. (204) 534-6184

Manufacturers of: _____
Gem Quad Ham Antennas

HINTS ON TUNING AND OTHER POINTS

Make sure there is approximately 25 db F/B ratio on 10 and 20, and about 20 db F/B on the 15 meter sections before worrying about SWR. The F/B ratio has quite an effect on SWR.

Check balun and wire - using a dummy load and a good SWR bridge - wire and balun should be flat. Remember, your antenna cannot show a lower SWR than that appearing in the feedline or associated balun.

If your SWR changes with the direction in which the antenna is pointing it may be due to proximity effect. (Other antennae, bulky structures, roof guttering and downspouts, metal structures, etc.) Try watching the S meter while attached to a fixed antenna. Rotate the unattached Quad. If the signal strength varies it could indicate that the trouble lies in the fixed antenna.

Check all solder joints. A check at the receiver end of the coax should indicate continuity through the antenna.

Keep leads of balun short with no extraneous loops. Wire leading from balun to feedline (or coax connector) must be kept short and parallel.

Some hams have used "feedline pruning" to successfully reduce SWR - when other methods fail. First add about 10 feet of coax to the feedline, then prune the feedline in about 3 to 4 inch increments, checking the SWR after each pruning until a satisfactory result is obtained. (This only changes the SWR into which the transmitter looks).

As an alternative to the balun, you can use a 13 foot length of RG11 - connectors at each end - this has been reported to give a flat response and reasonable SWR on the three bands.

Due to the compromise effective in the spacing of the directors of the 3 and 4 element Gem Quads, it is suggested that a transmatch or antenna tuner be used where SWR is considered of great importance.

We have found that the simplest way of attaching the spider to the mast is to use the rotator as the joining instrument. Where this is impossible, or considered undesirable, the use of an appropriately sized sleeve should be considered. Make sure that sleeve and bolts are secure, using shims if necessary. Any movement in the joining will result in wear.

Gem Quad

Manufacturer of
Gem Quad Ham Antenna

Box 291, Bolsevaln, Manitoba, Canada R1K 0E0
Telephone (204) 534-6184
Fax (204) 534-6184

TENTATIVE ARRANGEMENT FOR FIVE BANDS

10 & 12 meter - one feed line.
15, 17 & 20 meter - one feed line.

OR

10, 12 & 15 meter - one feed line.
17 & 20 meter - one feed line.

OR

10, 15 & 20 meter - one feed line with balun.
12 & 17 meter - feed each with 1/4 wave of 75 ohm coax.

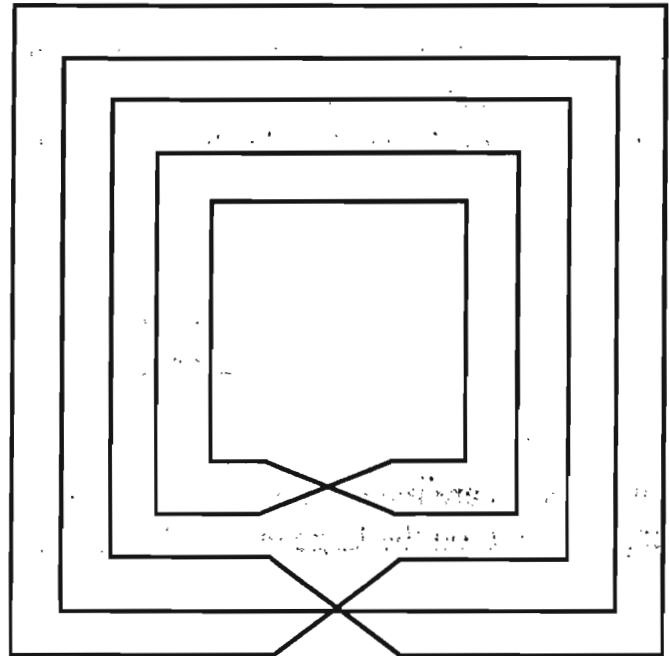

We have received reports that all five bands terminated into one coax/balun has resulted in satisfactory results. Also all five bands have been fed together with ladder line and terminated into a tuner with good results. As you can see the options are endless, use which ever system you feel will give you the best performance.

FREQUENCY	PLACEMENT OF ELEMENTS AND ELEMENT LENGTHS						
	ELEMENT LENGTH			POINT ON ARM			
	DRIVEN	REF.	DIR	DRIVEN	REF	DIR.	STUB
18.118 MHZ.	54'4"	55'0"	50'6"	121.5"	124.0"	112"	14.0"
24.94 MHZ	39'8"	40'10"	37'3"	87.5"	89.0"	80.5"	14.0"

Please note that the measurements on the other side of this page are for direct feeding the 12/17 meter elements. If you are connecting the 12/17 meter band to the common single balun feed point with 10/15/20 meters. Please adjust the driven element (MD) attachment point on the arm to the following position:

17 MD	117.0 inches
12 MD	85.0 inches

The 10/15/20 meter elements have been designed for a single feed line and a common feed point. If you elect to feed all bands with a separate feedline The driven element (MD) attachment point on the arm should be adjusted to the following approximate locations:

10 MD	77 INCHES	1'9.56
15 MD	104 INCHES	2'6.42
20 MD	156 INCHES	3'9.62

Measurements are made from the end of one of the three 1/4 inch rods protruding from the fiberglass wrap on the large end of the spreader.

Gem Quad Products 1987 Ltd.

Manufacturer of
Gem Quad Ham Antenna

Box 291, Boissevain, Manitoba, Canada R0K 0E0
Telephone (204) 534-6184
Fax (204) 534-2403

FOR GEM QUAD USERS

STEP # 1

Use a separate wire for the jumper wire. If you use the element wire as part of the jumper the driven elements will be too short. Use a flexible type of wire for the jumper 2" - 3" long.

Connect the three element wires to each side of the balun.

Connect a jumper to each set of element wire and to each side of the balun terminal.

Wires and jumpers have been omitted from the drawing to simplify the diagram.

STEP #2

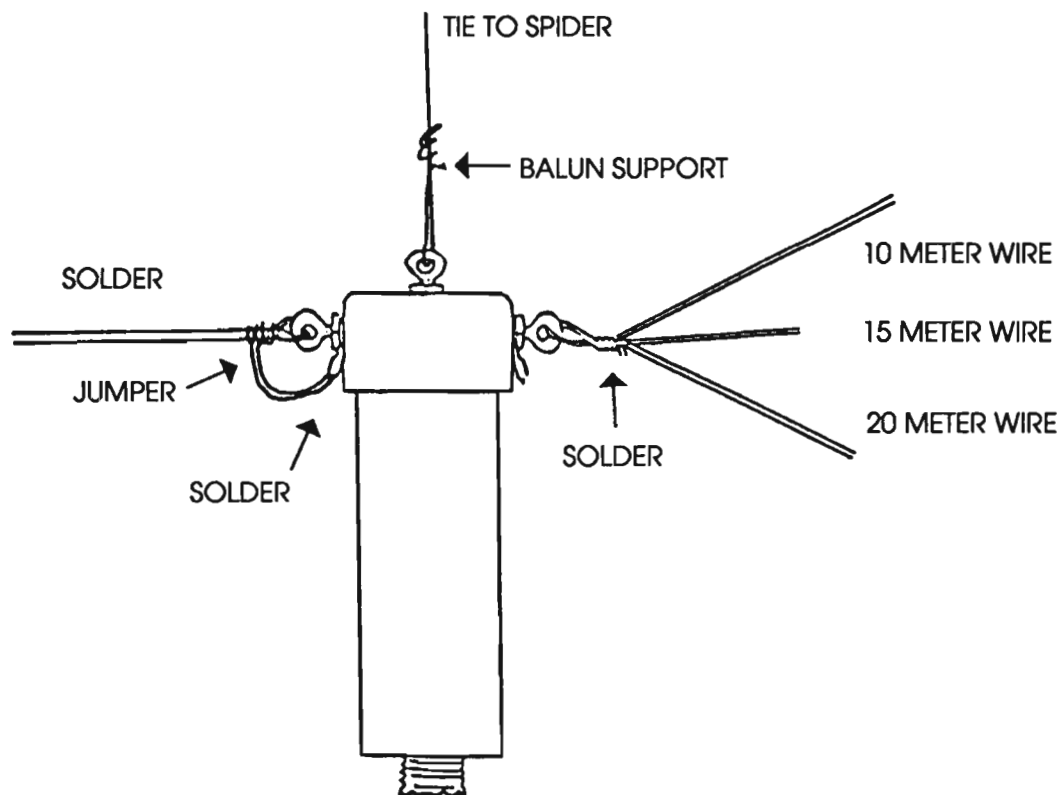

Gem Quad

Manufacturer of
Gem Quad Ham Antenna

Box 291, Boissevain, Manitoba, Canada R0K 0E0
Telephone (204) 534-6184
Fax (204) 534-6184

TWO METER ANTENNA (for use inside the regular Gem Quad)

1. To add this antenna to your previously assembled Gem Quad, measure off 81.5" (207 cm) of enamel covered wire. Clean each end with sandpaper. Solder both ends to a coax fitting (S0239); (one end to the center, the other end to the ground).
2. Measure 15.5" (39.3 cm) up each of the driven blue marked arms and attach the driven wire loop to this point using a tyrap, **DO NOT TIGHTEN**, just insert the tail of the tyrap into the lock sufficient for it to hold. Fig. 2.
3. Repeat this with each of the driven arms until you have the wire loop attached to all four arms. Make sure the coax connector is in the vertical plane as in fig. 2. Now bring the wire loop into reasonable square by carefully tightening each of the tyraps a bit at a time. The driven element is now ready for the attachment separate from the one used for the other bands.
4. The reflector is made in the same manner. Cut off 85.5" (217 cm) of wire, clean and solder the ends together to form a closed loop. Measure 16" (41 cm) up the reflector red marked arms and attach the reflector loop in the same manner as in the driven loop. When all four corners are attached, carefully adjust tyrap to tighten the wire loop into a reasonable square.

The two meter quad is now ready to go on the air.

NOTE: Figures given are for 144-146 Mhz.
NOTE: Some hams have found that 300 ohm feed with 4:1 balun works well. We have always used direct feed with coax.

(A) 20 3/8" Dr.
21 3/8" ref.

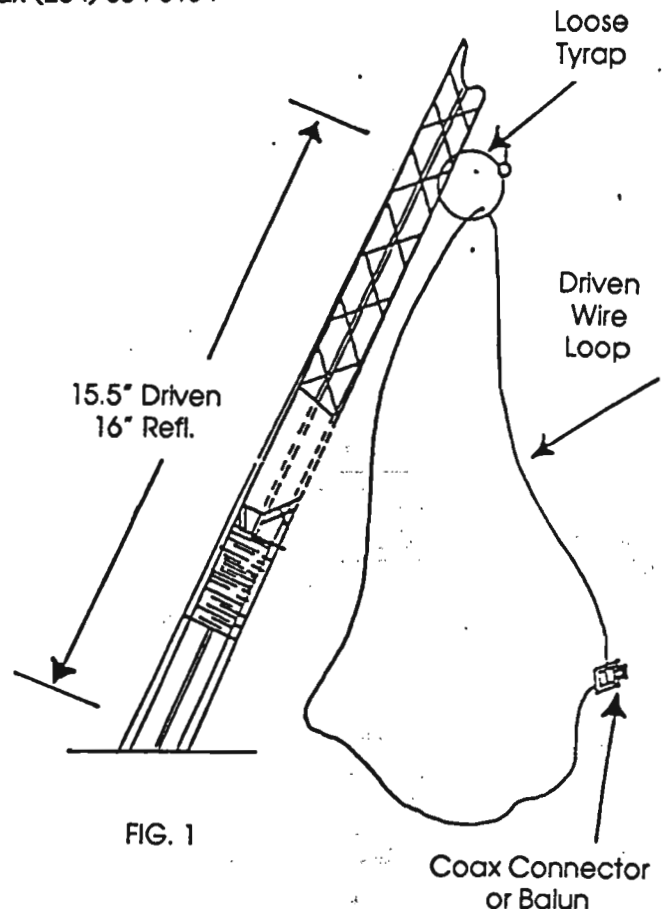

FIG. 1

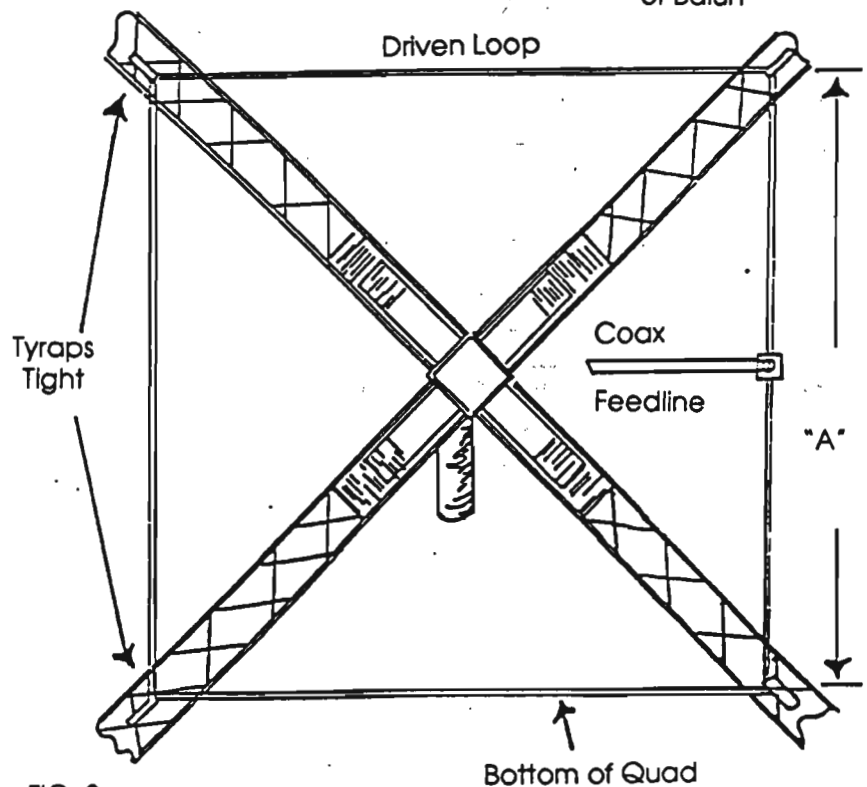

FIG. 2